

Rooftop Support Systems

MUSTANG MINI SPLIT STAND



Heavy-Duty Support Without the Heavy Lifting

The Mustang Mini-Split Stand is the ultimate lightweight equipment support: affordable strength and effortless assembly. Mustang Mini-Split Condenser Stands provide an off-the-shelf equipment support solution for holding your condenser equipment, mini-split units, heat pumps and more.

Constructed of durable, lightweight, and cost-effective metal framing, these stands are partially preassembled, with component hardware pre-attached, and take only minutes to put together, saving time and labor.

- Off-the-Shelf Solution with Preassembled Components
- Weighs Only 34 lbs. but Supports up to 300 lbs.
- Assembles in Minutes with Just a Wrench

Rated for up to 300 pounds, the Mustang Mini-Split stand closely competes with heavier and larger supports on the market, making it a Heavy-Duty Support, without the heavy lifting. Choose from non-penetrating, anti-slip rubber bases or direct mount options.

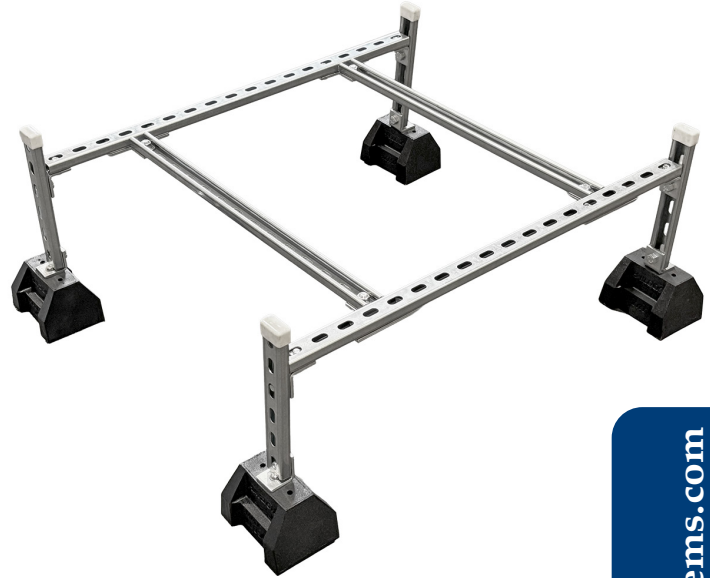
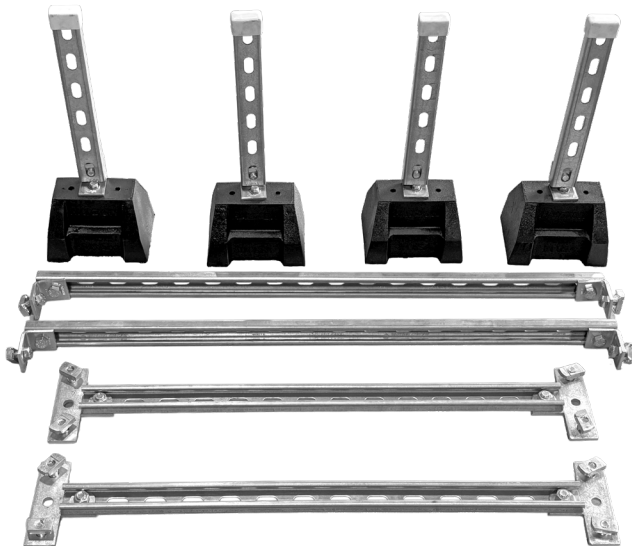

Product Options

Part Number: RTSEQ-MUSTANG-[PG/HG/SS/PC]

Extenders: RTS-MUSTANGEXT-[PG/HG]

Extenders are available to chain units together. Two are needed for each unit-to-unit connection.

Bases: Non-Penetrating Rubber, or Direct Mount

Finishes: Pre-Galvanized (PG), Hot Dip Galvanized (HG), Stainless Steel (SS), Powder Coated Steel (PC)

The Perfect Solution for Clustered Units

Whether holding single or multiple units on your rooftop or at ground level, the Mustang Mini Split Condenser Stand offers a reliable and convenient out-of-the-box solution for rooftop equipment support.

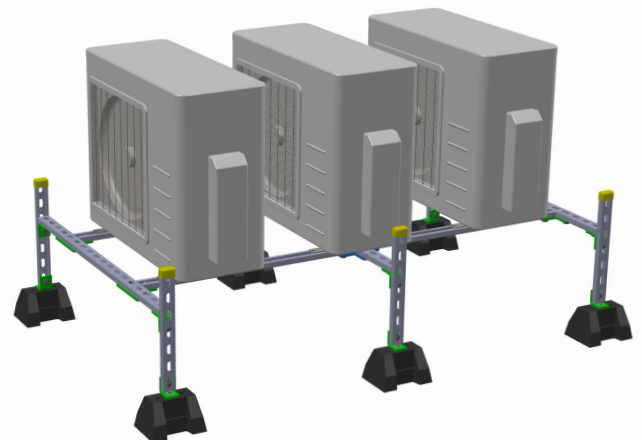

rooftopsupportsystems.com



Revolutionizing the Way You Think About Rooftop Supports



RTS Division: Providing our customers with innovative and economical solutions for non-penetrating rooftop support systems. Our environmentally friendly systems dampen vibrations, helping to extend roof life, while providing stable support for your high cost equipment and systems.

What We Offer

We offer a full range of customized rooftop support components designed to fit the needs of your specific application, making RTS the best choice for:

- Pipe Supports
- Conduit Supports
- HVAC Duct Supports
- Equipment Supports
- Maintenance Platforms
- Access Platforms
- Crossovers
- Walkways

Our systems have been engineered for strength, durability, stability and adjustability, using a superior array of square tubing, channel, fittings and hardware. All rubber components are manufactured from environmentally conscious, 100% recycled rubber materials.



Detailed product specifications are available for download on our website:

rooftopsupportsystems.com

What We Can Do For You

We'll save you both time and labor with our fully engineered and pre-built Rooftop Support Systems.

The versatility and adjustability that has been engineered into our component-based designs ensures a quick and easy installation process for you and your crew.

Complete your rooftop job in a fraction of the time that it would take using traditional methods.

- There is no more need for measuring, cutting, welding, or other time consuming activities at your job site.
- Components can be assembled in place, on your rooftop, and adjusted to suit your application.

Our quality rooftop supports are weather and UV resistant for high performance in a variety of conditions.

Engineering peace of mind through quality and innovative products.

Contact Information

RTS@eberliron.com

rooftopsupportsystems.com



EBERL IRON WORKS, INC.[®]

Serving the Needs of Our Customers Since 1923

128 Sycamore Street
Buffalo, New York 14204
Toll-Free: (888) 243-2669
Local: (716) 854-7633
Fax: (716) 854-1184
rooftopsupportsystems.com

