

Rooftop Support Systems

a division of Eberl Iron Works, Inc.
128 Sycamore Steet
Buffalo, New York 14204

(888) 243-2669
RTS@eberliron.com
rooftopsupportsystems.com



RTSRAMP-3

PRODUCT SUBMITTAL SHEET

CROSSOVER RAMP

Description

Crossover ramp units utilizing 12 gauge framing, anti-slip grating, and non-penetrating recycled rubber bases to provide safe pathways over rooftop obstacles for maintenance traffic.

Product Information

Compatible Bases: RTSF21

Clearance: 10-7/8 in from top of roof

Maximum Load Weight: 36 in width - 460 lbs, 42 in width - 400 lbs, 48 in width - 350 lbs

Framing: Welded and single 1-5/8 in x 1-5/8 in, 12 gauge strut channel

Grating: 11-3/4 in and 9-1/2 in wide x 1-1/2 in high, 12 gauge anti-slip plank grating with 10 gauge carrier angles

Framing/Grating Finish: Pre-Galvanized (G90), Hot Dip Galvanized (ASTM 123), or 304 Stainless Steel

Hardware Finish: Electro-Galvanized (ASTM B633), Hot Dip Galvanized (ASTM 123), or 304 Stainless Steel

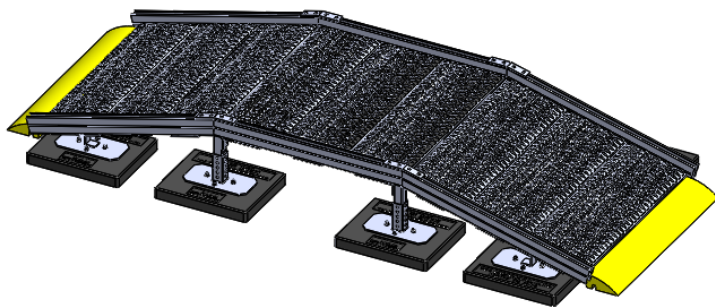

Installation

1. Place bases on roof per design layout
2. Insert 1-5/8 in x 1-5/8 in strut uprights into square tube receiver on bases. Secure each with (1) 3/8 in channel nut and bolt (19 ft/lbs). All other framing hardware is 1/2 in tightened to 50ft/lbs
3. Attach grating to the platform sides (1-5/8 in x 3-1/4 in welded channel without bevel) to the grating with 1/2 in hardware
4. Attach to tops of 1-5/8 in strut uprights with 90 degree fitting and 1/2 in hardware
5. Repeat the process of attaching grating for the two ramp assemblies. This framing has 15 degree bevels on one end
6. Attach ramp assembly to platform using 15 degree fitting and 1/2 in hardware
7. Attach framing to base beneath ramps
8. Place transition piece at the end of each ramp

Quantity:

Contractor:

Project:

RTSRAMP-3

PRODUCT SUBMITTAL SHEET

