

Rooftop Support Systems

a division of Eberl Iron Works, Inc.
128 Sycamore Steet
Buffalo, New York 14204

(888) 243-2669
RTS@eberliron.com
rooftopsupportsystems.com



RTSEQ-MDF-1

PRODUCT SUBMITTAL SHEET

SINGLE UNIT SUPPORT

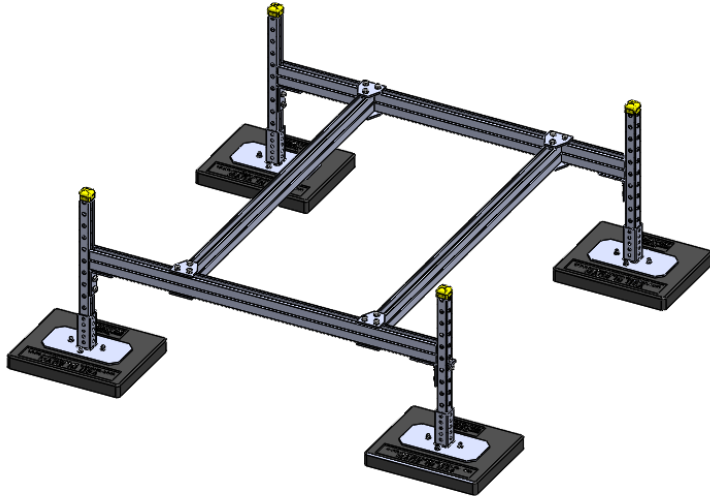

Description

Non-penetrating and adjustable condenser support consisting of strut channel framing and recycled rubber bases for safely supporting HVAC units.

Product Information

Compatible Bases: RTSF21

Clearance: Adjustable height 12 in - 24 in

Maximum Load Weight: 500 lbs total. 500 lbs/unit

Framing: Welded 1-5/8 in x 3-1/4 in solid, and 1-5/8 in x 1-5/8 in perforated, 12 gauge strut channel

Framing Finish: Pre-Galvanized (ASTM 653), Hot Dip Galvanized (ASTM 123), or 304 Stainless Steel

Hardware Finish: Electro-Galvanized (ASTM B633) or 304 Stainless Steel

Installation

1. Place base on roof based on design layout
2. Preload (1) 3/8 in channel nut and bolt into one of the top two holes on the base receiver
3. Insert upright components into bases with strut opening facing outward. Tighten bolt to 19 ft/lbs to secure
4. Attach 90 degree brackets to uprights at approximate height of unit using 1/2 in hardware. Hand tighten
5. Install welded channel framing to the 90 degree brackets to form the ends of the support. Level in all directions and tighten hardware to 50 ft/lbs
6. Attach the remaining welded channel to the top and bottom of the welded channel using the plate fittings provided. Align the strut with mount holes on the unit and tighten to 50 ft/lbs
7. Install yellow caps on the tops of the upright

Quantity:

Contractor:

Project:

