

## Rooftop Support Systems

a division of Eberl Iron Works, Inc.  
128 Sycamore Steet  
Buffalo, New York 14204



(888) 243-2669



RTS@eberliron.com



rooftopsupportsystems.com



# RTSEQ-LDF-5

PRODUCT SUBMITTAL SHEET

## FIVE UNIT SUPPORT

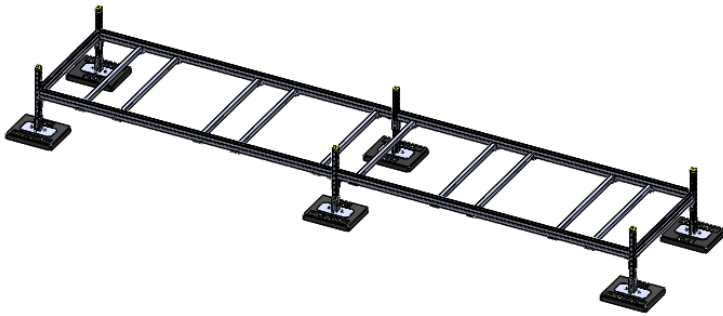

## Description

Non-penetrating and adjustable condenser support consisting of strut channel framing and recycled rubber bases for safely supporting HVAC units.

## Product Information

**Compatible Bases:** RTSF21

**Clearance:** Adjustable height 12 in - 24 in

**Maximum Load Weight:** 1250 lbs total. 250 lbs/unit

**Framing:** Welded 1-5/8 in x 3-1/4 in solid, and 1-5/8 in x 1-5/8 in perforated, 12 gauge strut channel

**Framing Finish:** Pre-Galvanized (ASTM 653), Hot Dip Galvanized (ASTM 123), or 304 Stainless Steel

**Hardware Finish:** Electro-Galvanized (ASTM B633) or 304 Stainless Steel

## Installation

1. Place base on roof based on design layout
2. Preload (1) 3/8 in channel nut and bolt into one of the top two holes on the base receiver
3. Insert upright components into bases with strut opening facing outward. Tighten bolt to 19 ft/lbs to secure
4. Attach corner brackets to uprights at approximate mount height of unit using 1/2 in hardware. Hand tighten
5. Install welded channel framing to the corner brackets to form the outer framing of the support. Level in all directions and tighten hardware to 50 ft/lbs
6. Attach the single strut to the underside of the welded channel using the plate fittings provided. Align the strut with mount holes on the unit and tighten to 50 ft/lbs
7. Install yellow caps on the tops of the upright

Quantity:

Contractor:

Project:

